

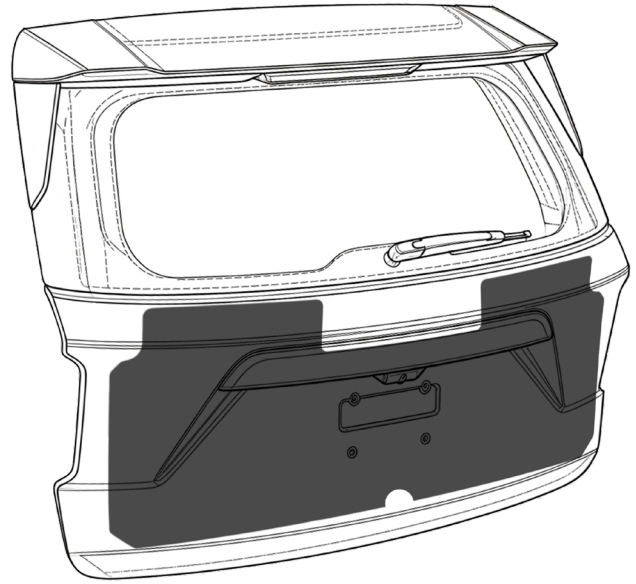

AVAIL[®]

VEHICLE HATCH

NIJ LEVEL IIIA



INSTALLATION GUIDE

As shown on

**FORD[®] POLICE
INTERCEPTOR UTILITY**
(2020 & newer models)



angelarmor.com

970 235 2961

avail@angelarmor.com

TABLE OF CONTENTS



INTRODUCTION	3 - 4
Product Description	3
Installation Overview	3
Warnings & Cautions	4
Legal Statements	4
TOOLS & PARTS LIST	5 - 7
Recommended Tools	5
Installation Kit Contents	6 - 7
INSTALLATION	8 - 12
Overview	8
- General	8
- Important Notes	8
Procedure	9 - 12
- Preparing the Hatch	9 - 10
- Installing the Vehicle Hatch Hardware	10 - 11
- Installing the Avail Vehicle Hatch	11 - 12
- Completing Installation	12
REMOVAL OR DECOMMISSION	12

© 2026 ANGEL ARMOR, LLC. ALL RIGHTS RESERVED. PRINTED IN THE U.S.A.

FORD® IS A REGISTERED TRADEMARK OF FORD MOTOR CORPORATION.

INTRODUCTION

Congratulations on your purchase of the Angel Armor® Avail® Vehicle Hatch (Level IIIA) for the Ford® Police Interceptor Utility (2020 & Newer)! It is our honor to provide advanced protection to those who put their life on the line in the name of law and order.

Your vehicle will soon be upfitted with the finest ballistic technology available. With optimized coverage area, a seamless design and powerful protection from NIJ Level IIIA handgun threats, Avail elevates vehicle protection to a higher level.

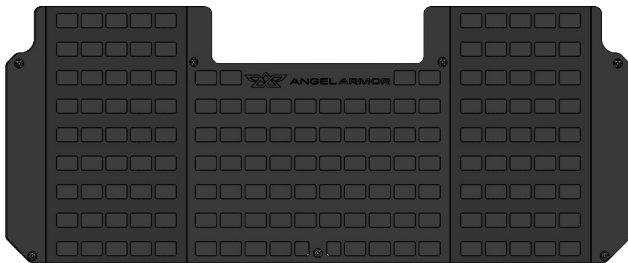

▲ Figure 1. Angel Armor Avail Vehicle Hatch (Level IIIA) for the Ford Police Interceptor Utility (2020 & Newer)

Product Description

Angel Armor Avail Vehicle Armor (Level IIIA) is constructed of a strong, thin, and lightweight proprietary technology made for optimal coverage below the rear-hatch glass. The Vehicle Hatch features an integrated MOLLE attachment platform for mounting equipment up to 20 lbs. for expanded functionality without sacrificing usable space. These properties, plus semi-rigid material characteristics, enable unprecedented ease of installation while providing protection independently tested in accordance with NIJ Standard 0108.01 protocol. Angel Armor Avail Vehicle Hatch (Level IIIA) for the Ford Police Interceptor Utility (2020 & Newer) exceeds NIJ Standard 0108.01 protocol for multi-round protection and offers a five-year express limited warranty. Within this period, the panel may be removed and transferred to another vehicle of the same make and model without violating the warranty.

Installation Overview

The ballistic Vehicle Hatch panel installation shown in this guide was performed on the hatch of the Ford Police Interceptor Utility.

Avail Level IIIA Vehicle Hatch armor features a simple installation starting with marking and removing the hatch trim. This is required to install the rivet nuts and standoffs that hold the vehicle armor. Once this is completed, the vehicle hatch is reassembled and the armor is secured in place. Installation takes approximately 45-60 minutes per vehicle hatch.

Warnings and Cautions







Please adhere to the following guidelines to prevent personal injury, equipment damage and unnecessary difficulty during installation.

Warnings and Cautions

Please adhere to the following guidelines to prevent personal injury, equipment damage and unnecessary difficulty during installation.

Legal Statements

See supplied Warranty and Terms and Conditions for important legal information. These instructions are provided for your convenience only, and Angel Armor expressly disclaims any liability for any damage to personal property or personal injury that occurs as a result of either installation or removal of panels.

-  Read this guide in its entirety before beginning installation.
-  Wear appropriate protective gear, including eye and foot protection.
-  Avoid puncturing speakers with screws, push-snaps, fasteners, or other sharp pieces during hatch disassembly, hatch re-assembly, and panel insertion.
-  Do not drop screws or other assembly components inside the hatch, as they may be difficult to retrieve. If possible, use magnetic tools during installation.
-  Use only plastic trim removal/prying tools on finished surfaces to help prevent scratching.
-  Discard and replace any hatch components that are inadvertently damaged during the installation process. Proper installation according to the instructions in this guide will not impair the hatch function in any way.
-  Use caution when removing parts that may have sharp edges.

TOOLS & PARTS LIST

This section lists the tools recommended for installation and the parts included in the installation kit.

Required Tools

- Panel pry tools



▲ Figure 2. Panel/trim removal tool

- Torx T27 key wrench (or screwdriver)



▲ Figure 3. Torx T27 key wrench



▲ Figure 4. Screwdriver

- Channel Locks or Wide Mouth Pliers



▲ Figure 5. Channel locks



▲ Figure 6. Wide mouth pliers

- Utility knife



▲ Figure 7. Utility knife

- Drill



▲ Figure 8. Drill

- “X” or 25/64” drill bit



▲ Figure 9. X drill bit



▲ Figure 10. 25/64 drill bit

- Step drill bit



▲ Figure 11. step drill bit

- Center punch



▲ Figure 12. center punch

- Rivet tool and 1/4-20 Mandrel



▲ Figure 13. Rivet tool



▲ Figure 14. 1/4-20 Mandrel

Recommended Tools

- De-burring tool
- Touch-up paint
- Magnetic retrieval tool
- Headlamp or flashlight

TOOLS & PARTS LIST

This section lists the parts included in the installation kit and the tools recommended for installation. Install kit contents are for one vehicle hatch.

Installation Kit Contents

- One IIIA Vehicle Hatch ballistic panel for Ford Police Interceptor Utility (2020 & Newer)



▲ Figure 15. Vehicle Hatch ballistic panel for Ford Police Interceptor Utility (2020 & Newer)

- One aluminum MOLLE panel

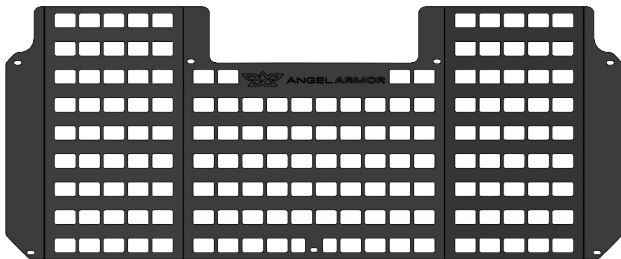

▲ Figure 16. Aluminum MOLLE panel

- Drill Appendix 1 & 2 (on pages 13, 14)

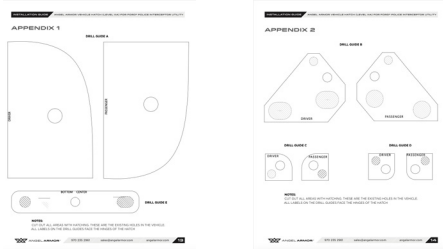

▲ Figure 17. Drill Appendix 1 & 2

- Five 1/4"-20 x .75" button head bolts and washers



▲ Figure 18. Five 1/4"-20 x .75" button head bolts and washers

- Two 1/4"-20 x 1" button head bolts and washers



▲ Figure 19. Two 1/4"-20 x 1" button head bolts and washers

- Seven 1/4"-20 rivet nuts



▲ Figure 20. Seven 1/4"-20 rivet nuts

- One 1" Male to Female standoff



▲ Figure 21. One 1" Male to Female standoff

- Two 2" Male to Female standoffs

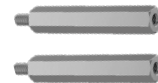

▲ Figure 22. Two 2" Male to Female standoffs

- Two 2.5" Male to Female standoffs



▲ Figure 23. Two 2.5" Male to Female standoffs

- Two 3" Male to Female standoffs



▲ Figure 24. Two 3" Male to Female standoffs

TOOLS & PARTS LIST (CONTINUED)

This section lists the parts included in the installation kit and the tools recommended for installation. Install kit

Installation Kit Contents

- Angel Armor brand label



▲ Figure 25. Angel Armor brand label

- Isopropyl alcohol wipe



▲ Figure 26. Isopropyl alcohol wipe

INSTALLATION

This section provides instructions for installing Angel Armor Avail Vehicle Hatch (Level IIIA) into the Ford Police Interceptor Utility (2020 & Newer).

Overview

Installation of Angel Armor Avail Vehicle Hatch (Level IIIA) into the Ford Police Interceptor Utility is simple and starts with removing the hatch trim. Once this is completed, the vehicle hatch can be reassembled and the armor is secured in place. See procedure on page 9 for detailed instructions.

General Installation Procedure

- 1 Remove hatch trim, and mark with drill guides.
- 2 Install rivet nuts and standoffs.
- 3 Reinstall hatch trim.
- 4 Install ballistic panel and aluminum MOLLE panel.

Important Notes

- The directions, photographs and illustrations in this guide depict an installation performed on the hatch.
- Note the location of screws and hatch components before disassembling to aid proper re-assembly before panel installation.
- Place all removed hardware and components in a safe place during installation.
- Angel Armor Avail Ballistic panels are semi-rigid, which allows them to be bent slightly for easy installation. To help prevent damage to the Vehicle Hatch Panels, do not bend them tighter than a 6" radius (12" diameter).
- Firm pressure may be needed to clear minor obstructions during insertion of the ballistic panels, but never use excessive force. Excessive force may damage hatch components.
- Bypass obstructions inside the hatch by angling the panel during insertion as described in Installing the Avail Vehicle Hatch, on page 11.

PROCEDURE

Complete the following steps to properly install Angel Armor Avail Vehicle Hatch (Level IIIA) for Ford Police Interceptor Utility.

Preparing the Hatch

- 1** Remove the hatch trim, starting from the top center and pulling down each side of the trim.
- 2** Align the drill guides with the bottom corners of the hatch interior trim.

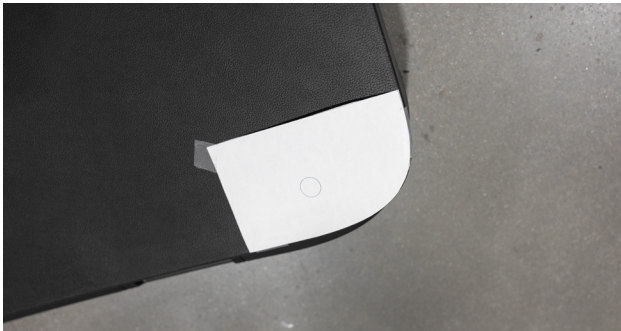

▲ Figure 27. Driver's side drill guide A aligned with bottom left corner of hatch interior trim

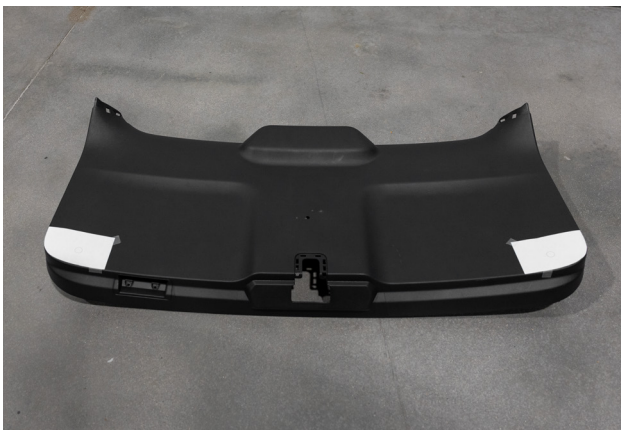

▲ Figure 28. Drill guides A (driver and passenger) aligned with bottom corners of hatch interior trim

- 3** Center punch each of the holes shown in the drill guide.



▲ Figure 29. Using drill guide template to center punch holes on the hatch interior

- 4** Hold the aluminum MOLLE panel up to the trim. Align bottom corner slots with center-punched holes. Center punch the remaining holes.



▲ Figure 30. Location of MOLLE panel when center punching remaining holes



▲ Figure 31. Marking center punch locations

- 5 Cut holes at all markings using a step drill bit.

NOTE: Modifications to the plastic rivet housings will need to be made using a utility knife. Ensure that modifications to the rivet housings do not affect the function of the rivet interaction to the door skin.

NOTE: Be sure not to damage the circled area of the rivet housing in Figure 32.



▲ Figure 32. Rivet housing after utility knife modifications

Installing the Vehicle Hatch Hardware

- 1 Align the drill guides with all locations shown in Figures 33 and 34.

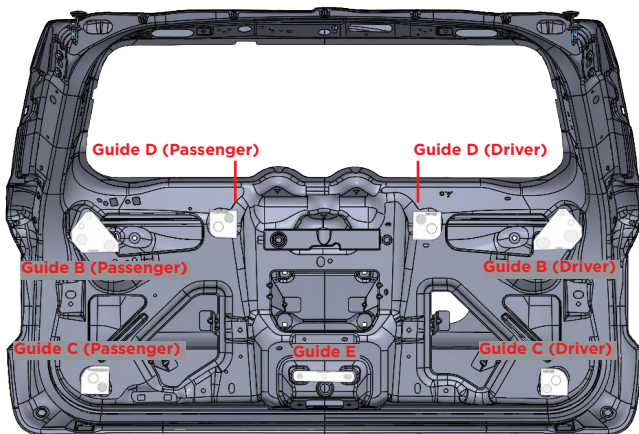

▲ Figure 33. Render of correct placement of drill guides on hatch

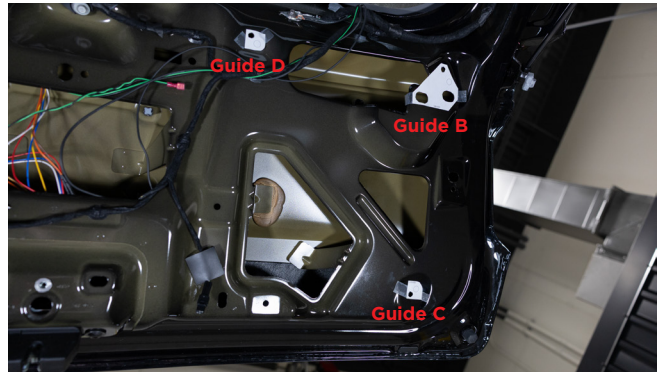

▲ Figure 34. Driver's side drill guides B, C, and D in their proper locations



▲ Figure 35. Location of driver's side drill guide A



▲ Figure 36. Location of driver's side drill guide C

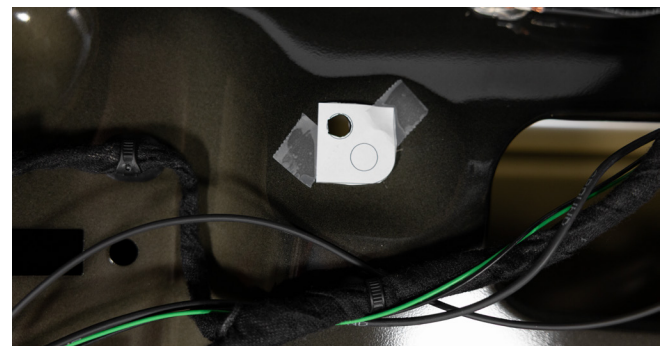

▲ Figure 37. Location of driver's side drill guide D

- 2 Drill out rivet nut holes with an "X" or 25/64" drill bit.

- 3** Install all seven rivet nuts using a rivet tool and a 1/4" mandrel.
- 4** Install the standoffs in their respective rivet nuts, referencing Figures 33 and 34 (pg. 10). This should include:
 - 1" Standoff (Drill Guide E)
 - 2" Standoffs (Drill Guide D)
 - 2.5" Standoffs (Drill Guide B)
 - 3" Standoffs (Drill Guide C)
- 5** Tighten standoffs with channel locks or wide mouth pliers.

Installing the Avail Vehicle Hatch

- 1** Reinstall all the trim pieces in reverse order of their removal.

NOTE: Rivet nut installation can warp the door skin. Use channel locks or pliers to realign the standoffs with the holes in the trim if needed.



▲ Figure 38. Standoff locations once trim pieces are reinstalled

- 2** Hold the aluminum MOLLE panel up to the door plastic and partially install four 0.75" bolts and washers in each corner using a T27 Torx key or screwdriver.

- 3** Slide the ballistic panel between the aluminum MOLLE panel and the hatch trim, with the Angel Armor logo facing the trim.

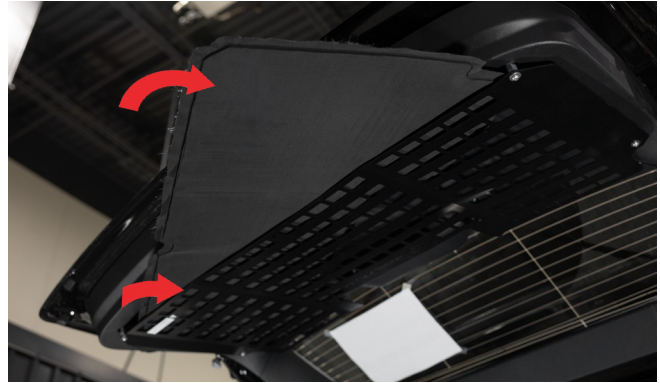

▲ Figure 39. Sliding ballistic panel between MOLLE panel and hatch trim

- 4** Partially install the remaining 0.75" bolt and washer into the standoff near the latch.
- 5** Partially install two 1" bolts and washers into the standoffs in the center below the window.
- 6** Tighten all Torx bolts to 6 ft-lbs.



▲ Figure 40. Final armor placement once bolts are tightened

Completing Installation

- 1 Ensure proper closure of the hatch.
- 2 Attach the Angel Armor brand label to the interior of the hatch by completing the following procedure:
 - A Clean the attachment location on the hatch with isopropyl alcohol.
 - B Allow the hatch surface to dry completely.
 - C Remove backing from the brand label.
 - D Apply the brand label to the hatch, pressing for at least 30 seconds to ensure proper adhesion.



▲ Figure 41. Angel Armor brand label

INSTALLATION COMPLETE:

Your vehicle is now equipped with advanced ballistic protection from Angel Armor.

REMOVAL OR DECOMMISSION

This section describes the process for removing the Vehicle Hatch for decommission or transfer to another vehicle.

- 1 Remove Angel Armor brand label.
- 2 Remove bolts from the three center standoffs.
- 3 Remove the Vehicle Hatch IIIA ballistic panel.
- 4 Remove all other bolts and MOLLE panel.
- 5 Remove all hatch trim pieces.
- 6 Remove all standoffs.

NOTE: Rivet nuts can be left in the hatch, as they will not interfere with proper function of the hatch.

- 7 Reinstall hatch trim.

- ⚠ If removing the Ballistic Panel for transfer to another vehicle, inspect the panel after removal. Contact Angel Armor with any concerns about wear or damage.

APPENDIX 1

DRILL GUIDE A

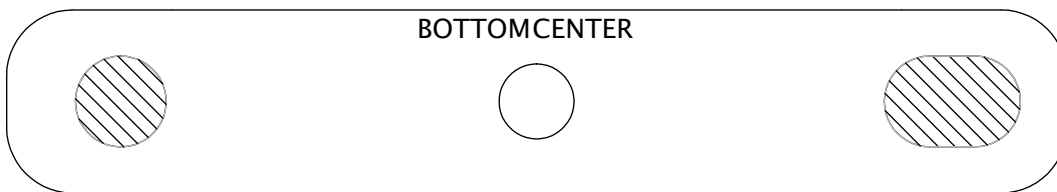
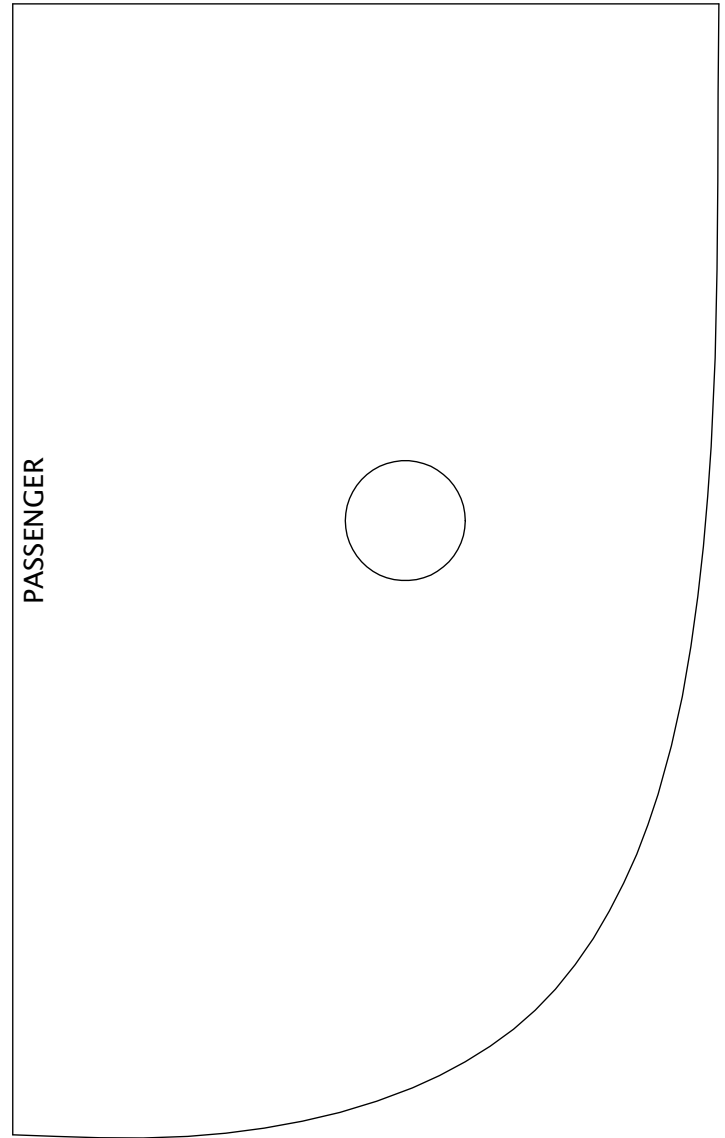
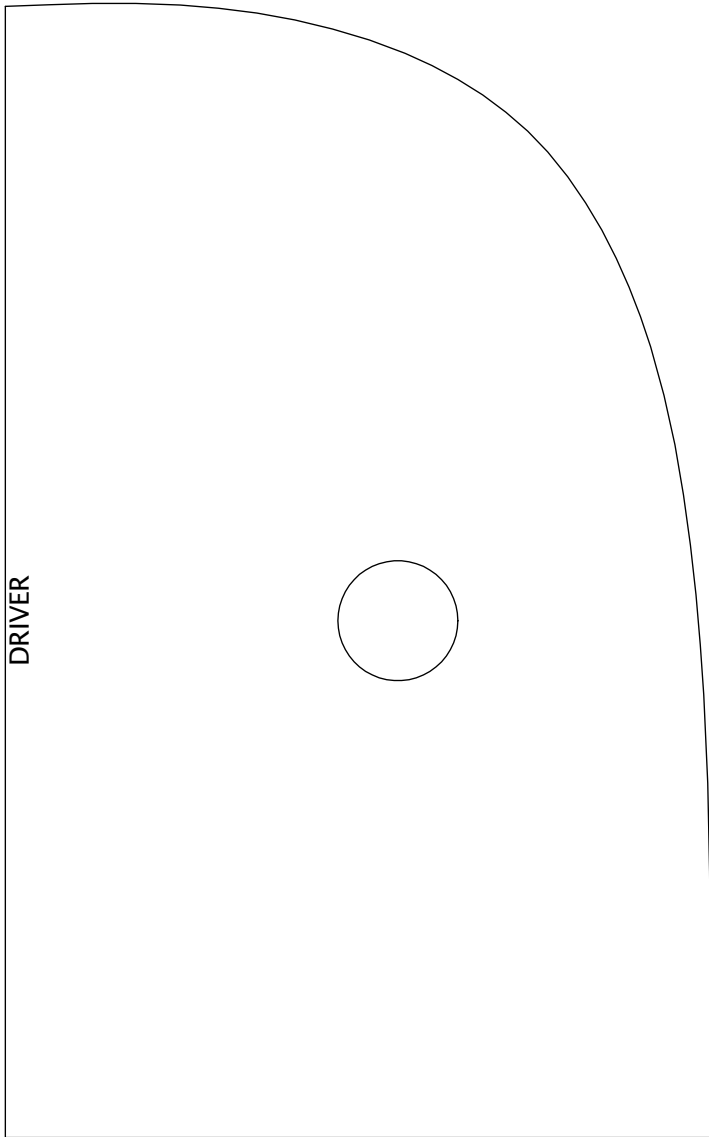

DRILL GUIDE E

NOTES:

CUT OUT ALL AREAS WITH HATCHING. THESE ARE THE EXISTING HOLES IN THE VEHICLE.
ALL LABELS ON THE DRILL GUIDES FACE THE HINGES OF THE HATCH

APPENDIX 2

DRILL GUIDE B

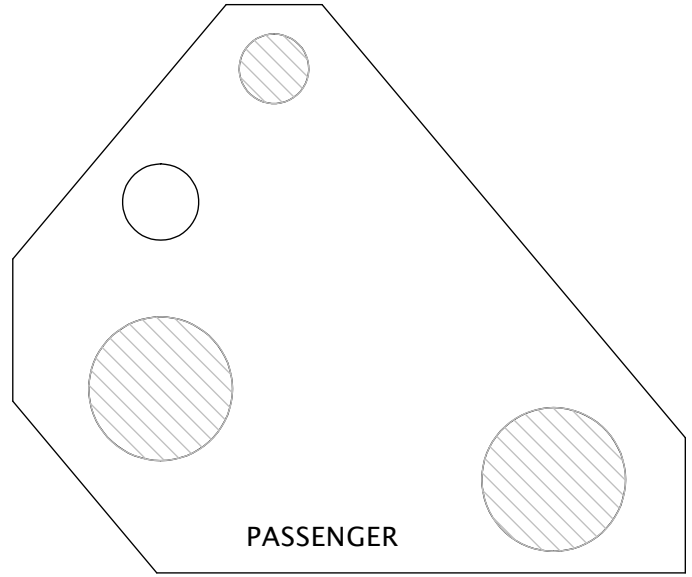
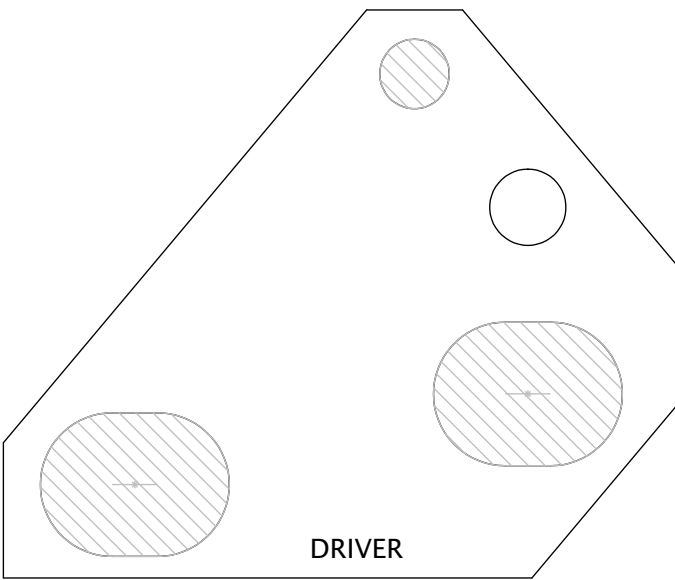

DRILL GUIDE C

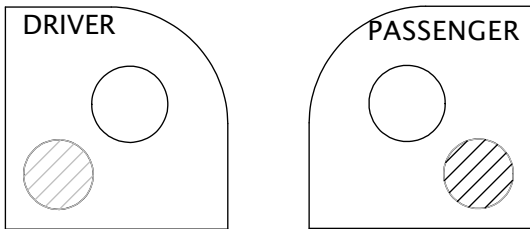

DRILL GUIDE D

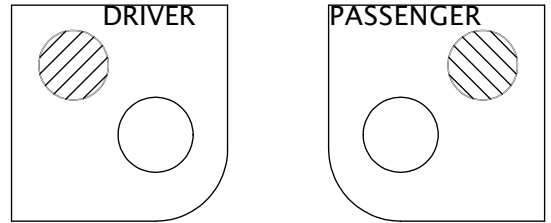

NOTES:

CUT OUT ALL AREAS WITH HATCHING. THESE ARE THE EXISTING HOLES IN THE VEHICLE.
ALL LABELS ON THE DRILL GUIDES FACE THE HINGES OF THE HATCH